



Scan for video

# LA-F2

## Industrial class air bubble system





- Ultra High Inflation level, maximum the protection.
- Up to 82 ft/min high-speed, enhance the productivity.
- 16-32 inch width film applied, universal for applications.
- Strong and durable sealing.
- Build in air pump, smaller footprint with less noise, easy to set up.



PN code	Description	Speed (ft/min)	Machine Size (inch)	Machine Weight (LBS)
60A01131	Industrial Class Air bubble machine	82	18x23x20	48.5

## Configurations

Model	FR8002	FR8003
		
PN code	60A11002	60A11015
Description	Roll winder	Roll winder
Max. film width (inch)	32	32
Dimension(LxWxH inch)	Expand:52x19x31.5 Collapse:31.5x19x34	29x29x46
Weight (LBS)	86	88

## Film Options:

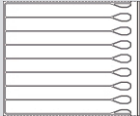
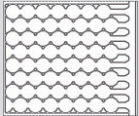
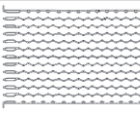
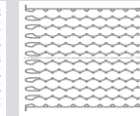
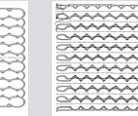
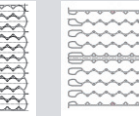
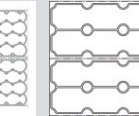
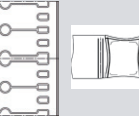
Series	MFA	MFB	MFB25	MFB32	MFB33	MFB40	MFC	MEX
Shape	Air tube	Ø1.7inch round bubbles	Ø1 inch round bubbles	Ø1.26 inch round bubbles	Ø1.3 inch round bubbles	Ø1.6 inch round bubbles	Air tube	Air pillow
Pattern								

PN code	Model	Material	Thickness (mil)	Width (inch)	Perforation (inch)	Roll Length (ft)	Roll/Pallet
90B01181	MFB-A-08-16-13-L	PA/PE	0.8	16	13	1476	120
90B01033	MFB-A-10-16-13-L	PA/PE	1.0	16	13	1476	120
90B01041	MFB-A-10-32-13-L	PA/PE	1.0	32	13	361	128
90B01232	MFB-A-14-16-6.5-L	PA/PE	1.4	16	6.5	1050	120
90B01080	MFB-A-14-16-13-L	PA/PE	1.4	16	13	1050	120
90B01183	MFB25-A-08-16-13-L	PA/PE	0.8	16	13	1969	120
90B01184	MFB25-A-10-16-13-L	PA/PE	1.0	16	13	1476	120